

OWNER'S MANUAL

- ☑ Safety Warnings
- ☑ Parts List
- ☑ Assembly and Operating Instructions
- ☑ Recipes
- ☑ Accessories



Patio Pro™

Model:1515

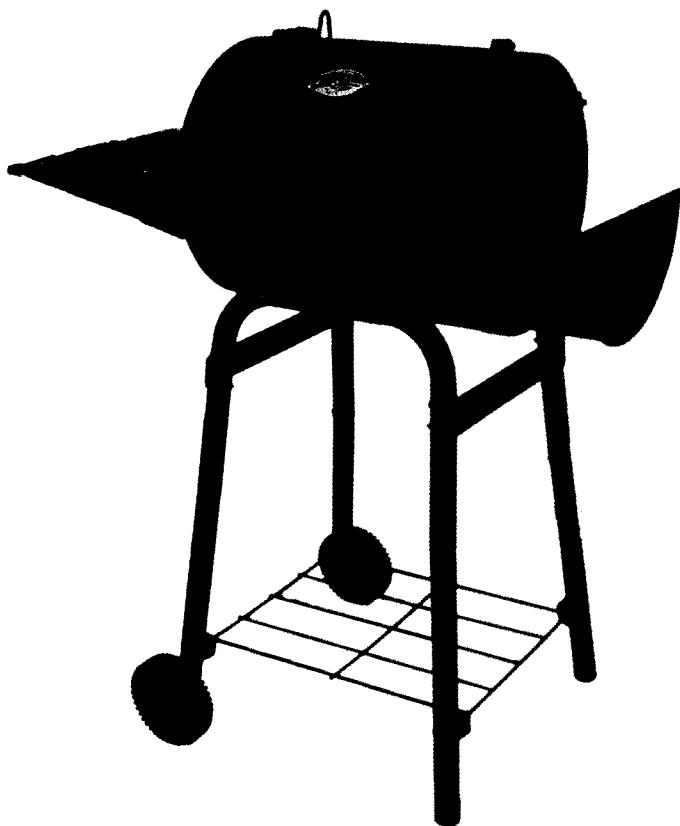

- ◆ **Side Air Vents**
(Dampers) Regulate heat and smoke
- ◆ **Heavy Steel Construction**
Welded seams Heavy duty...Built to last for Years
- ◆ **Side Shelf**
Holds plates, sauces, and tools
- ◆ **Double Steel Bottom**
Protects from burnout while keeping heat in
- ◆ **Side Drawer**
For Easy access to coals and ashes
- ◆ **Hinged Lid**
For Easy access to cooking area
- ◆ **Wood Handle**
Stay cool handle
- ◆ **Cooking Grate**
Supports 23 lbs. of food in a 250" area
- ◆ **Cast Iron Grates**
Even heat
- ◆ **Fire Grate**
Holds coals off the bottom for more even heat
- ◆ **Ash Pan**
For easy clean up
- ◆ **Wheels**
For easy mobility

• **Dump Ash Pan**

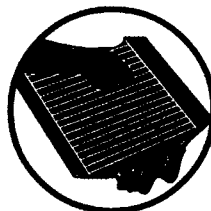

Easy Clean-up

Visit www.chargriller.com

IMPORTANT SAFETY WARNINGS



**READ ALL SAFETY WARNINGS AND INSTRUCTIONS CAREFULLY
BEFORE ASSEMBLING AND OPERATING YOUR GRILL.**



WARNING

- Use caution when assembling and operating your grill to avoid scrapes or cuts from sharp edges.
- Do not use gasoline, kerosene or alcohol for lighting charcoal. Use of any of these or similar products could cause an explosion possibly leading to severe bodily injury.
- Keep children & pets away from grill. Supervision is necessary and do not leave grill unattended when in use. Use caution when moving grill to prevent strains. Keep grill at least 15 feet from any combustible material (decks, buildings, fences, trees, bushes, etc.).
- When adding charcoal and/or wood, use extreme caution.
- Never move grill when it is in use or when it contains hot coals or ashes.
- Do not place grill near flammable liquids, gases or where flammable vapors may be present.
- Use caution since flames can flare-up when fresh air suddenly comes in contact with fire. When opening the lid, keep hands, face and body safe from hot steam and flame flare-ups.
- Do not exceed a temperature of 400°F. Do not allow charcoal and/or wood to rest on the walls of grill. Doing so will greatly reduce the life of the metal and finish of your grill.
- Always wear oven mitts to protect hands from burns. Avoid touching hot surfaces.
- When opening lid, make sure it is pushed all the way back so it rests against the lid support brackets. Use extreme caution as hood could fall back to a closed position and cause bodily injury.
- Close lid and all dampers to help suffocate flame.
- Never leave coals and ashes unattended. Before grill can be left unattended, coals and ashes must be removed. Use caution to protect yourself and property. Carefully place remaining coals and ashes in a noncombustible metal container and saturate completely with water. Allow coals and water to remain in metal container 24 hours prior to disposing.
- To protect against bacteria that could cause illness, keep all meats refrigerated and thaw in refrigerator or microwave; keep raw meats separate from other foods; wash everything that contacts raw meats; cook thoroughly; and refrigerate leftovers immediately.

**STOP! CALL US FIRST!
DO NOT RETURN TO STORE.**

CALL  AT (912) 638-4724

This product has been built to the highest quality standards. Call us should you have any questions which are not addressed in the instructions, or for service information.

ASSEMBLY INSTRUCTIONS

▲ Read all safety warnings and instructions carefully before assembling and operating your grill.

The following tools are required for assembly:

- Pliers
- 7/16" Wrench, Adjustable Wrench, or Nut Driver

PARTS LIST:

- 1 Cooking chamber
- 2 Damper circle
- 2 Cast Iron Grates
- 1 Metal rod handle
- 1 Wood handle
- 1 Wire rack (for wood)
- 4 Legs (6 pieces)
- 1 Side Drawer / Ash pan / Fire grate
- 1 Side shelf Assembly
- 2 Wheels
- 1 Cast Iron Lifter
- 1 Lock Bracket

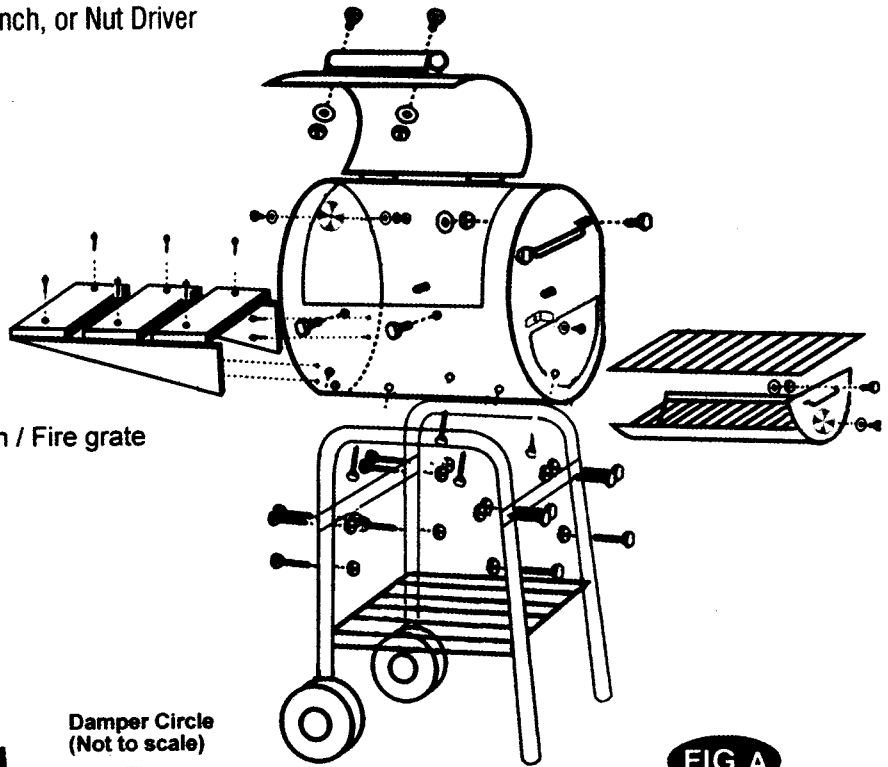

PARTS BAG CONTAINS:

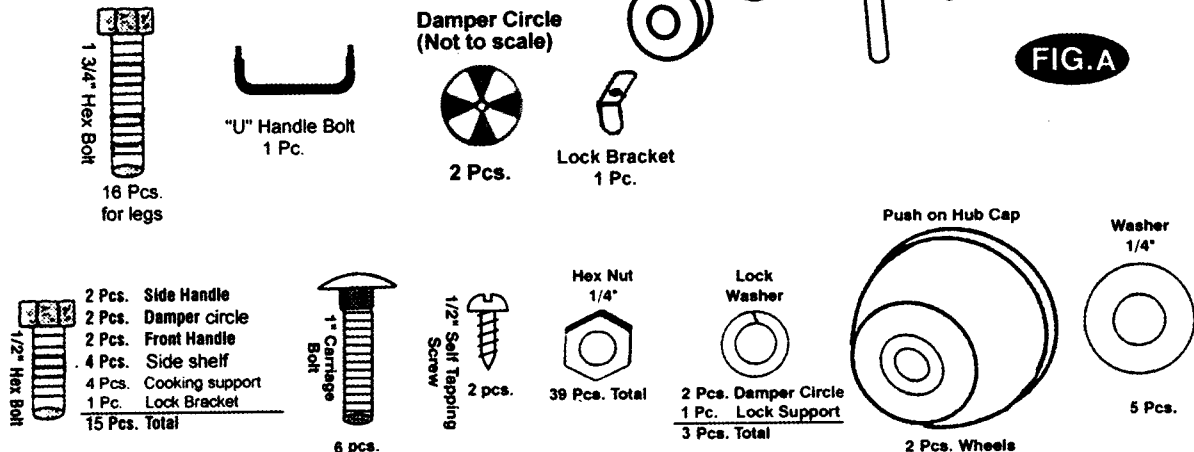

FIG. A

ASSEMBLY INSTRUCTIONS

 **Read all safety warnings and instructions carefully before assembling and operating your grill.**

1. Remove and unwrap the Patio Pro and all of its parts from the packaging. Also remove the ash drawer from the Patio Pro. Place GRILL on its end with damper opening facing up. Spread lid open in order to reach inside to perform the following.

2. Insert two BOTTOM LEG into one TOP LEG. Attached with 1 3/4" hex bolt and nut, See Fig.1 & A Repeat this step for another two BOTTOM LEGS and one TOP LEG. See Fig.1.

3. Attach LEG BRACES to the outside of one of the TOP and BOTTOM LEG assemblies you just made, See Fig.2. Use two 1 3/4" hex bolts and nuts for each LEG BRACE, but only finger tight.

4. Insert all four corners of the BOTTOM WIRE SHELF into the four holes located near the bottom inside of the four LEGS. See Fig.3. Next, rotate the LEGS upward until vertical. Important: Make sure the two Long Legs are on the same end and the Axles on the Short Legs toward outside.

5. Attach the other end of the LEG BRACES to the corresponding legs using 1 3/4" Hex Bolts and Nuts but only finger tight. See Fig.4.

6. Slide a WHEEL onto AXLE then gently hammer the a HUB CAP onto AXLE. Repeat this step for another wheel and Hub Cap. See Fig.5.

7. Stand the CART/LEG ASSEMBLY upright. Attach the Grill body to the CART/LEG ASSEMBLY (make sure damper is on same side as wheels), with four 1 3/4" Hex Bolts. There are two holes in the front and two in the back of the Grill Body. See Fig.6.

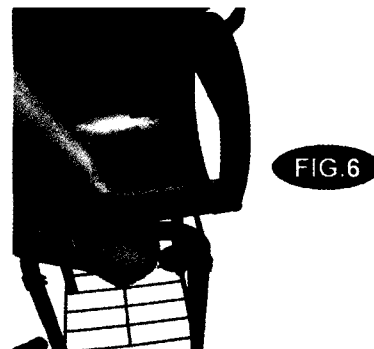
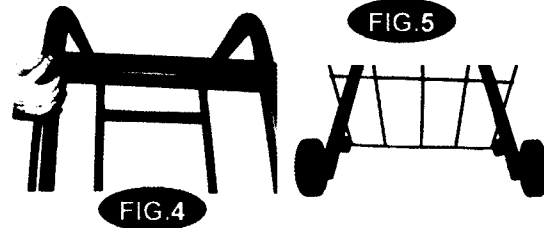
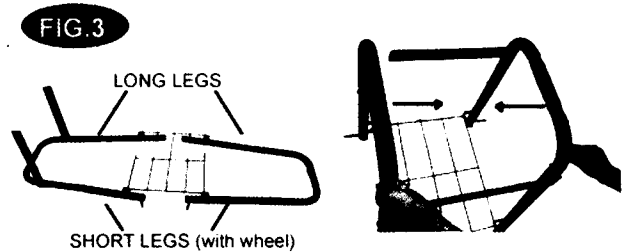
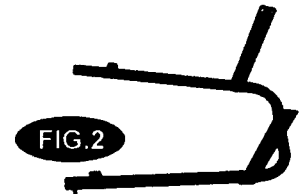
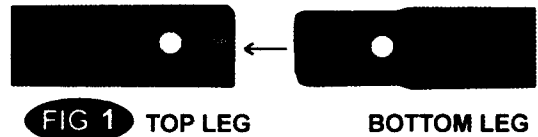

8. Attach WOOD HANDLE with (2) 1/2" HEX BOLTS to center of front edge of hood; next attach LOCK WASHERS & HEX NUTS to BOLTS. Snug tight with pliers.FIG.A&7

9. Attach SIDE HANDLE (metal rod) to the END of the GRILL above SIDE DRAWER with (2) 1/2" HEX BOLTS,(2) LOCK WASHERS, and (2) HEX NUTS. FIG. A&7

10. Attach LOCK BRACKET to the End of the GRILL between SIDE HANDLE and SIDE DRAWER with one 1/2" hex bolt, one flat washers, one lock washer and one nut. FIG. A&7

11. Attach two (2) SIDE SHELF BRACKETS to the four (4) holes on left side of grill with 1/2" hex bolts and nuts. Next, attach three (3) WOOD SLATS to the brackets with six(6) 1" carriage bolts and nuts. Then, holding shelf straight, screw two(2) 1/2" screws through bracket and into outer wood slat from underneath. Holes are only in brackets, not wood for these two(2) screws. FIG.7&A.

12. Attach the Damper circle to the inside of the Ash Drawer using one 1/2" hex bolt, two flat washers, one lock washer and one nut. The bolt goes thru a Flat Washer, thru the Ash Drawer wall, thru the Damper Circle, thru another Flat Washer, thru Lock Washer, and finally attached to a Hex Nut. Fig.A.

13. Attach the "U" Handle Bolt to the side of the Ash Drawer using two lock washers and nuts. Fig.A.

14. Attach the Damper circle to the inside of the left grill damper opening using one 1/2" hex bolt, two flat washers, one lock washer and one nut. Fig.A.

15. Tighten ALL Nuts and Bolts.

16. Place the grate into the ash drawer then slide the ash drawer into the FIRE BOX then place the cook grate into the FIRE BOX.

NO RETURNS ON USED GRULLS.

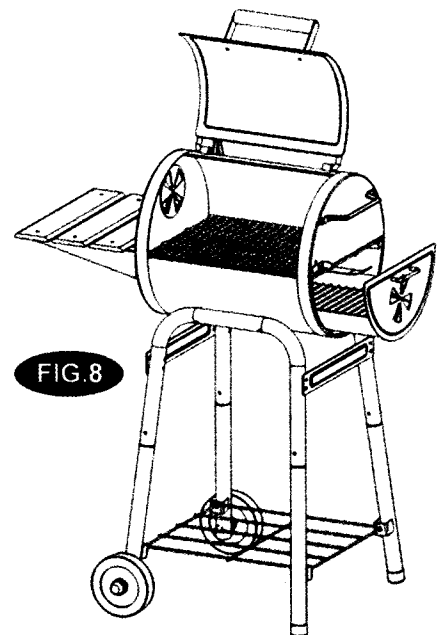
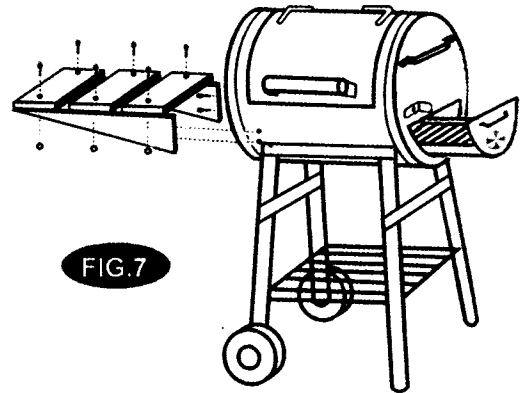

GRILL PREPARATION & OPERATING INSTRUCTIONS



Read all safety warnings and instructions carefully before assembling and operating your grill.

1. Cure GRILL prior to your initial use to protect the exterior finish and to prevent unnatural flavors to your first meals. (A) Lightly coat all interior surfaces (including GRILLS and GRATES) with vegetable oil. (B) Build a medium size fire on the FIRE GRATE and replace COOKING GRATE. (C) After coals ash over, close LID and burn at 250 degrees for two hours. Your GRILL will then be ready for use.
Never exceed 400 degrees.
2. To START FIRE - stack approx. 15 briquets in pyramid and saturate with lighter fluid (DON'T USE GASOLINE). Light coals in several places, close lid after briquets ash over or 1/2 gray, spread them out and start cooking. If one end burns faster, use tongs to move coals from one end to the other for even heat. ALWAYS  FOLLOW CHARCOAL AND LIGHTER FLUID MANUFACTURERS' INSTRUCTIONS AND WARNINGS. USE OUTDOORS ONLY ON NONCOMBUSTIBLE SURFACE - 15' AWAY FROM WOOD AND COMBUSTIBLE MATERIAL.
3. Control the heat with the DUAL DAMPERS and the ADJUSTABLE FIRE GRATE.
4. For no flare-ups, cook with lid in the down position. Add water soaked hardwood chips for a smoked flavor.
5. Burn out may be rust out. Ashes left in bottom too long hold moisture and rust through any thickness of steel.
6. Do not use self-starting charcoal as it will give unnatural flavor. Burn off lighter fluid completely before closing lid.
7. After using, wipe INTERIOR while warm and apply vegetable oil on grills and inside body which comes in contact with fire to reduce rust. On the EXTERIOR, remove any rust and touch up with a high heat paint.

RECIPES

Grilling - Direct Method

Cook food directly above coals. Generally speaking, to grill meats, raise fire grate to high position (hot) and sear for one minute on each side with the lid open to seal in flavor and juices. Then lower fire grate to medium position with lid closed and cook to desired doneness. Control heat with dual dampers.

STEAK – Season to taste with salt, pepper, or garlic salt and place on cooking grid. To seal in flavor and juices, sear steaks with fire grate in highest position for 1 or 2 minutes on each side with lid up. Then lower fire grate and close lid. Finish cooking each side 5 to 10 minutes depending upon the thickness and desired doneness. Turn steaks twice. Grill approximately 5 minutes per side for rare 1" thick steaks; and 10 minutes per side for 2" thickness.



MARINATED FLANK STEAK – Mix marinade ingredients in nonmetal dish. Let steak stand in marinade for no less than 4 hours in refrigerator. Brown each side for 5 minutes, but center should remain rare. Cut steak diagonally across the grain into thin slices before serving.

RECIPES

Grilling - Direct Method (continued)

Grill with fire grate in high (hot) position and lid open or closed.

MARINADE: 1/2 cup vegetable or olive oil, 1/3 cup soy sauce, 1/4 cup red wine vinegar, 2 tbs. lemon juice, 1 tsp. dry mustard, 1 minced clove garlic, 1 small minced onion, 1/4 tsp. pepper.

QUAIL OR DOVES – Cover birds in Italian dressing (Good Seasons or Kraft Zesty), marinate overnight, pour off dressing and cover with Texas Pete Hot Sauce for 6 hours. Wrap birds in thick bacon secured by a toothpick. *Place on grill – keep turning until bacon is black. Grill for 20 minutes. Sear with lid open and fire grate in high (hot) position for 1 min. each side before lowering grate and closing lid. *OR SMOKE by placing birds in center of GRID with fire in both ends of FIRE BOX.

KABOBS – Alternating on skewers any combination of meat, onions, tomatoes, green peppers, mushrooms, zucchini, circular slice of corn-on-the-cob, or pineapple. Meat could consist of chunks of shrimp, scallops, lobster, chicken, sausage, pork, beef, etc. Marinate the meat in refrigerator for several hours. Grill each side approximately 7 minutes turning occasionally while basting with marinade. Leave a small amount of room between pieces in order to cook faster. Grill with lid up and the fire grate in the lowest position. See marinade recipe on last page.

However, if you choose foods with a wide variety of cooking times, place on separate skewers. The following is approximate cooking time for kabobs. Put onions and potatoes on first (35-40 mins.); secondly put on meat brushed with Bar-B-Q sauce or plain meats (20-25 mins.); marinated meats (15-20 mins.); mushrooms (15-20 mins.); cherry tomatoes (5-10 mins.) Soak wooden skewers in water one hour so that they won't burn.

IOT DOGS – Grill with lid up and fire grate in high (hot) position for approximately 6 minutes, turn every few minutes.



HAMBURGERS – Mix in chopped onions, green peppers, salt, sear 3/4 inch patties on each side with fire grate in high position for a few minutes. Lower fire grate to medium position and grill with lid down to avoid flare-ups. Cook each side 3 to 7 minutes according to desired doneness. Cook ground meat to 150° internally or until juice runs clear (free of blood) for prevention of Ecoli.

Burgers can be basted with marinade when turning and/or other ingredients can be mixed in with the ground beef such as chili sauce or powder; or you may marinate by allowing to stand in marinade for 1 or 2 hours at room temperature before cooking; or let stand in covered dish in refrigerator up to 24 hours. Bring to room temperature before cooking. See meat marinade on last page.

SHRIMP (Peeled) & Crayfish – Place on skewers, coat with melted butter and garlic salt. Grill 4 minutes on each side or until pink. Cocktail sauce optional.

BAKED POTATOES – Rub with butter and wrap in foil and cook on grill with lid down for 50 minutes. Turn after 25 minutes (no need to turn if smoked). Squeeze for doneness.

SWEET CORN IN HUSKS – Trim excess silk from end and soak in cold salted water 1 hour before grilling. Grill 25 minutes - turning several times.



SWEET CORN IN FOIL – Husk and wash. Rub with butter and season with salt and pepper. Wrap each ear in foil and grill for 30 minutes turning several times (no need to turn if smoked).



GRILLED VEGETABLES – Slice 1/4" thick and soak in olive oil prior to grilling to prevent burning. Grill for 9 minutes each side.